



Q4P09H: STORAGE AND LIGHT DUTY SERVICE 4-Post Pre-Facility Checklist

HEIGHT REQUIREMENTS

Step 1: Determine drive under height

- Use your vehicle height and round up to nearest height under runway on locks (d)

- Height under runway on locks:

67.75" 63.25" 58.5" 54" 49.25" 44.75" 40"
35.5" 30.75" 26.25" 21.5" 17" 12.25" 7.75"

Step 2: Determine vehicle height above runway

- Use your vehicle height (b)

Step 3: Determine overall height and clearance

a.	Minimum clearance to overhead		2"
b.	Vehicle height above runway (step 2)	+	<input type="text"/>
c.	Runway thickness	+	5"
d.	Drive under height (step 1)	+	<input type="text"/>
	Required overall height	=	<input type="text"/>

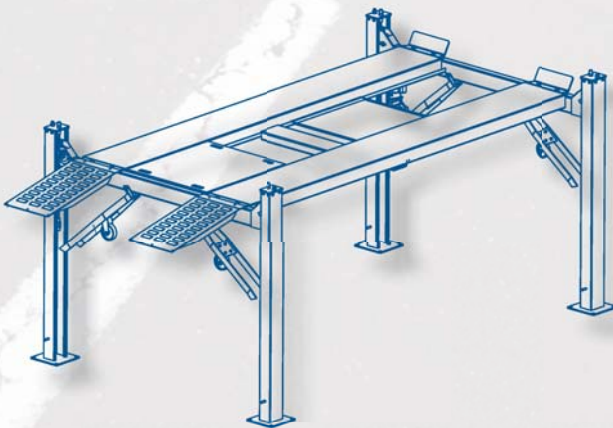
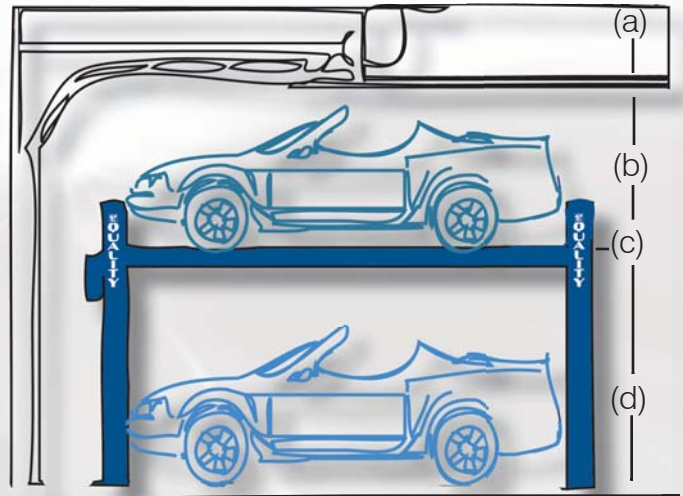

Q4P09H OVERALL DIMENSIONS

Overall Width	112"	
Overall Length	211"	(with approach ramps)
Height of Columns	86"	
Width of Runways	20"	
Between Runways	38"	
Length of Runways	164"	(max wheelbase 155 3/4")
Removable Approach Ramps	36"	

*See backside to complete form.



**Order installation option and save 67% on freight charges
and get 1 Year Labor Warranty
Call 1-877-771-5438 for details!**



www.qualitylifts.com

Fax: 502-583-5488



Q4P09H: STORAGE AND LIGHT DUTY SERVICE 4-Post Pre-Facility Checklist

SPACE REQUIREMENTS

Step 1: Use drawings below to ensure sufficient space.

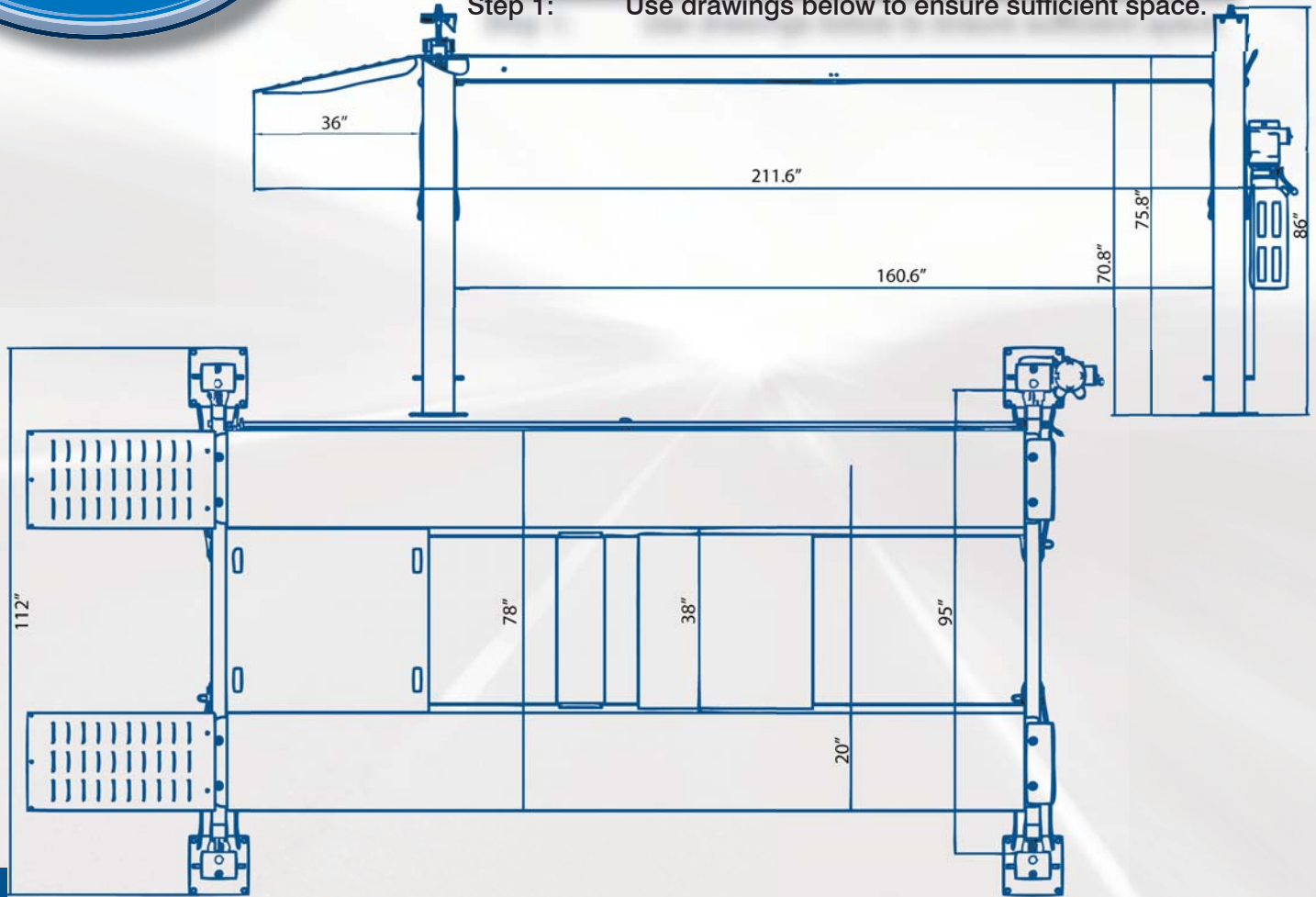

BILL TO:

NAME:			
ADDRESS:			
CITY:			
STATE:		ZIP:	
BILL TO PHONE #:			

SHIP TO:

NAME:			
ADDRESS:			
CITY:			
STATE:		ZIP:	
SHIP TO PHONE #:			
COMMERCIAL	OR	RESIDENTIAL	(circle one)

OWNER PRE-INSTALLATION CHECKLIST

1. Is the floor level?
(Slope not more than 1/8" per 1 foot)
2. Is the floor concrete?
(should only be used on concrete surface.)
3. Is the location inside?
(Installing outside should only be accomplished with special protection)
4. Is the required height sufficient?
(Use the height calculation from worksheet on front)
5. Is the required space sufficient?
(Determine required space calculation from drawings above)
6. Do you have equipment available to offload 2,000 lbs.
(If no, we can help you make arrangements.)

Yes	No

SIGNATURE: _____

DATE: _____



Order installation option and save 67% on freight charges
and get 1 Year Labor Warranty
Call 1-877-771-5438 for details!



www.qualitylifts.com

Fax: 502-583-5488